

# AUTO DRAIN VALVE

Series NA1

Cat No APA - 01

**AUTO DRAIN VALVE** suitable for Filter Series F13, F14, F15 and F17  
Filter Regulator combination series FRC13, FRC14, FRC15 and FRC17

## Features

- Individual unit (Externally mountable)
- Low operating pressure
- Compact size
- Elegant design and finish
- Long life

## Function

These Auto drain units are externally mountable on G1/4, 3/8 and 1/2, 3/4, 1 size Filters and FRC units.

As the condensed water collects in the drain unit, the float moves up and drains the water.

The condensate water can also be drained manually.

A plastic tube can be fitted at the bottom of the auto drain unit to take the drained water away from the unit.

## Technical Specifications

Ordering No.	A2D01/MB	A2D02/MB	A2D03/MB
Size	1 / 4	3 / 8	1 / 2, 3 / 4, 1
Medium	Compressed air		
Operating pressure (bar)	2 - 10 bar		
Ambient Temperature	0 - 60° C		
Installation	Vertical (as in the picture)		
Materials of construction	Aluminium, Brass, Acetal, Stainless steel, Nitrile		

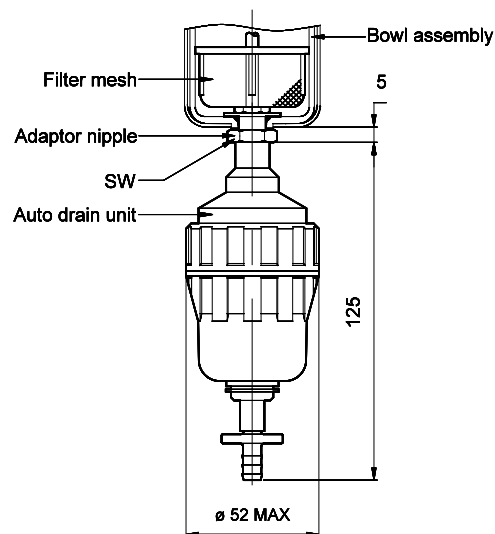

Size	SW	Ordering no.
G1/4	19	A2D01/MB
G3/8	19	A2D02/MB
G1/2, G3/4, G1	22	A2D03/MB

## Note

When ordered as A2D01/MB, auto drain unit with a adaptor kit and a filter mesh for G1/4 Filter or FRC will be supplied.

Subject to change